







INDUSTRIAL MOTORISED SIREN

10S

Mechanical Warning Siren

AUSTRALIAN DESIGNED & MANUFACTURED

 <p>Up to 10 km Effective range</p>	 <p>138 dB(A) Sound Output @ 1m</p>	 <p>Continuous Duty cycle</p>	 <p>Aluminium Construction</p>	 <p>IP56 Protection</p>	 <p>Global Delivery</p>
---	---	---	--	---	---

PRODUCT OVERVIEW

The Sirenco 10S is a high-output industrial mechanical siren designed for refineries, construction, civil defence, heavy industry and mining. Continuous-duty operation supports critical alerting across major sites.

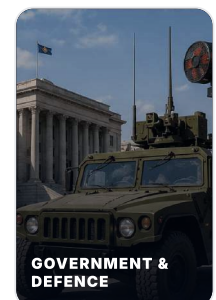
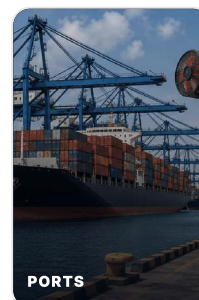
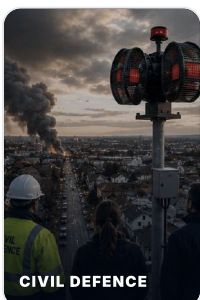
TYPICAL APPLICATIONS

ENGINEERING DRAWING

240V / 415V OPTIONS

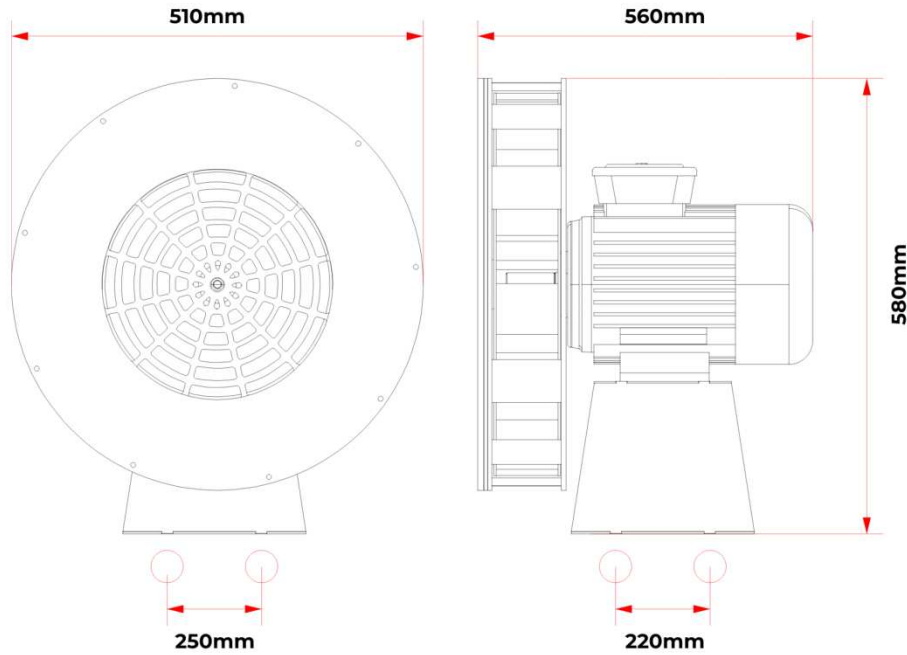

SPECIFICATION DATA

PERFORMANCE	
Sound output	138 dB(A) @ 1m
Effective range	Up to 10 km
Frequency	560 Hz
Duty cycle	Continuous
CONSTRUCTION	
Construction	Aluminium fabrication
IP rating	IP56
Operation	Horizontal and level
Mounting	Base / pole mount
DIMENSIONS	
Dimensions	510 x 560 x 580 mm
Weight	53 kg
Packaging size	56 x 66 x 66 cm
Shipping weight	65 kg
Mounting centres	250 x 220 mm

ELECTRICAL OPTIONS

240V Single Phase	
PART NUMBER: S10S230	
Voltage	Frequency
220/240V	50Hz
Phase	Running current
Single Phase	12.5A
Starting current	
On request	

415V Three Phase	
PART NUMBER: S10S400	
Voltage	Frequency
380/415V	50Hz
Phase	Running current
Three Phase	5A
Starting current	
On request	

ORDERING INFORMATION

Part Number	Model	Voltage	Frequency	Phase
S10S230	10S	220/240V	50 Hz	Single Phase
S10S400	10S	380/415V	50 Hz	Three Phase