







INDUSTRIAL MOTORISED SIREN

15D

Mechanical Warning Siren

AUSTRALIAN DESIGNED & MANUFACTURED



 <p>Up to 15 km Effective range</p>	 <p>145 dB(A) Sound Output @ 1m</p>	 <p>Continuous Duty cycle</p>	 <p>Aluminium Construction</p>	 <p>IP56 Protection</p>	 <p>Global Delivery</p>
---	---	---	--	---	---

PRODUCT OVERVIEW

The Sirenco 15D is a powerful dual-ended mechanical siren engineered for critical wide-area warning. Its 145dB(A) output and approximate 15,000m effective range support civil defence, defence installations and major industrial operations.

TYPICAL APPLICATIONS

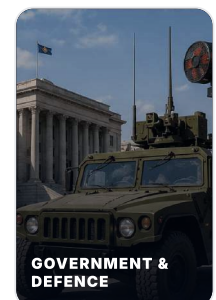
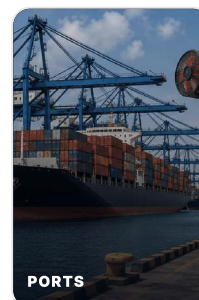
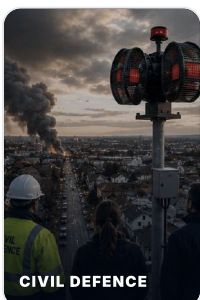

ENGINEERING DRAWING

415V / 480V THREE PHASE

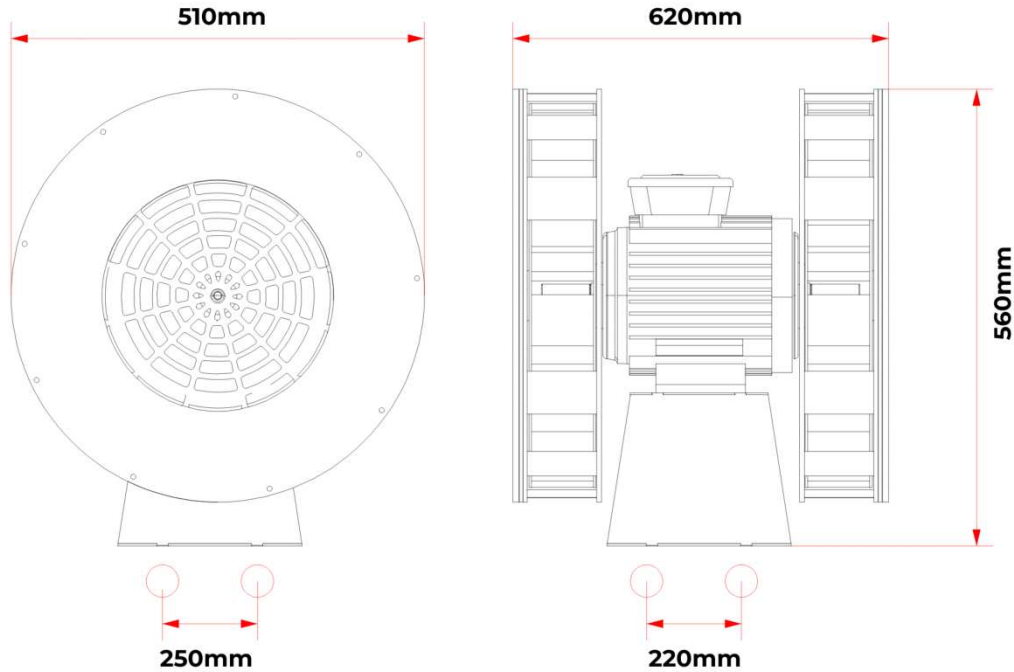

SPECIFICATION DATA

PERFORMANCE	
Sound output	145 dB(A) @ 1m
Effective range	Up to 15 km
Frequency	480 / 560 Hz
Duty cycle	Continuous
CONSTRUCTION	
Construction	Aluminium fabrication
IP rating	IP56
Operation	Horizontal and level
Mounting	Base / pole mount
DIMENSIONS	
Dimensions	510 x 620 x 560 mm
Weight	83 kg
Packaging size	56 x 66 x 63 cm
Shipping weight	95 kg
Mounting centres	250 x 220 mm

ELECTRICAL OPTIONS

415V Three Phase PART NUMBER: 15D400	
Voltage	380/415V
Frequency	50Hz
Phase	Three Phase
Running current	7A
Starting current	On request

480V Three Phase PART NUMBER: 15D480	
Voltage	208/480V
Frequency	60Hz
Phase	Three Phase
Running current	15/6A
Starting current	On request

ORDERING INFORMATION

Part Number	Model	Voltage	Frequency	Phase
15D400	15D	380/415V	50 Hz	Three Phase
15D480	15D	480V	60 Hz	Three Phase