







INDUSTRIAL MOTORISED SIREN

3S

**Mechanical
Warning Siren**

**AUSTRALIAN DESIGNED &
MANUFACTURED**



 <p>Up to 3 km Effective range</p>	 <p>126 dB(A) Sound Output @ 1m</p>	 <p>Continuous Duty cycle</p>	 <p>Aluminium Construction</p>	 <p>IP56 Protection</p>	 <p>Global Delivery</p>
--	---	---	--	---	---

PRODUCT OVERVIEW

The Sirenco 3S is a compact industrial mechanical siren engineered for dependable warning coverage across factories, construction sites, quarries and mining operations. Its cast aluminium weatherproof housing is designed for reliable outdoor service.

TYPICAL APPLICATIONS

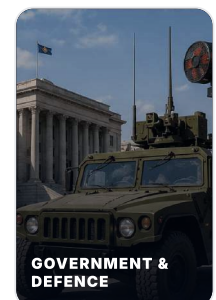
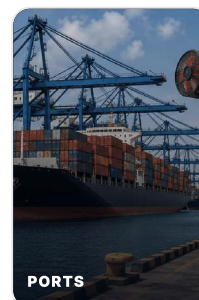
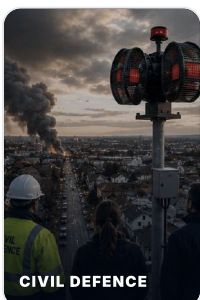

ENGINEERING DRAWING

240V / 415V OPTIONS

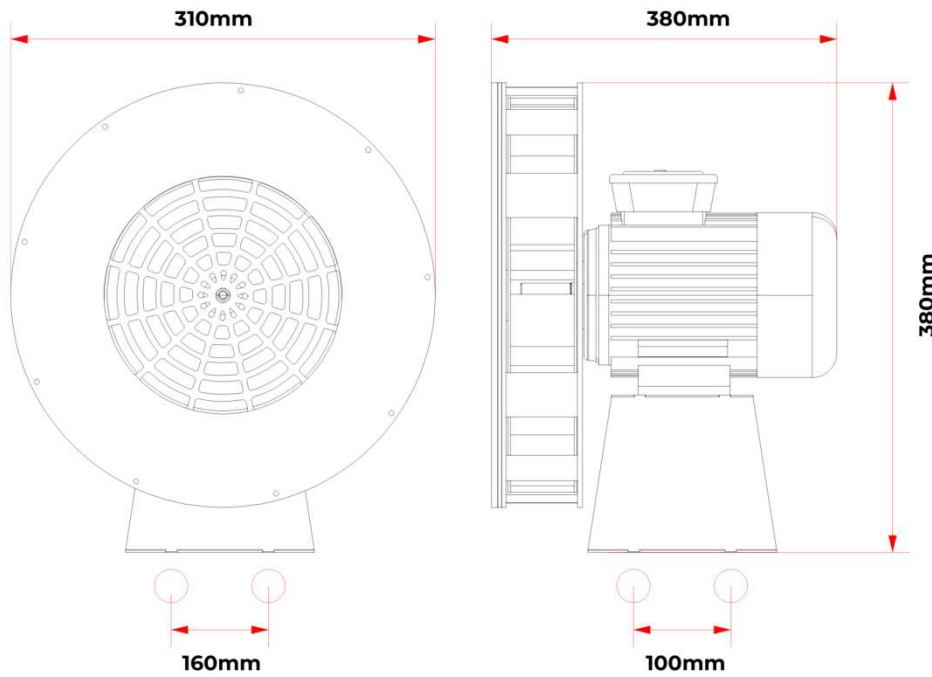

SPECIFICATION DATA

PERFORMANCE	
Sound output	126 dB(A) @ 1m
Effective range	Up to 3 km
Frequency	560 Hz
Duty cycle	Continuous
CONSTRUCTION	
Construction	Aluminium fabrication
IP rating	IP56
Operation	Horizontal and level
Mounting	Base / pole mount
DIMENSIONS	
Dimensions	310 x 380 x 380 mm
Weight	25 kg
Packaging size	40 x 42 x 48 cm
Shipping weight	33 kg
Mounting centres	160 x 100 mm

ELECTRICAL OPTIONS

240V Single Phase	
PART NUMBER: S3S230	
Voltage	Frequency
220/240V	50Hz
Phase	Running current
Single Phase	6A
Starting current	
On request	
415V Three Phase	
PART NUMBER: S3S400	
Voltage	Frequency
380/415V	50Hz
Phase	Running current
Three Phase	3A
Starting current	
On request	

ORDERING INFORMATION

Part Number	Model	Voltage	Frequency	Phase
S3S230	3S	220/240V	50 Hz	Single Phase
S3S400	3S	380/415V	50 Hz	Three Phase